



Quick Installation Guide

Long-rang Outdoor Wireless Transmitter

WI-CPE513P-KIT Hardware Version: V3

www.wireless-tek.com

1.Packing Content

- WI-CPE513P-KIT



Wireless Transmitter x 2



PoE Adapter x 2



Metal Tie Cable x 2



Ethernet Cable x 2

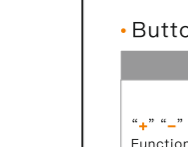

Quick Installation Guide x 2

2.Hardware Overview

- WI-CPE513P-KIT

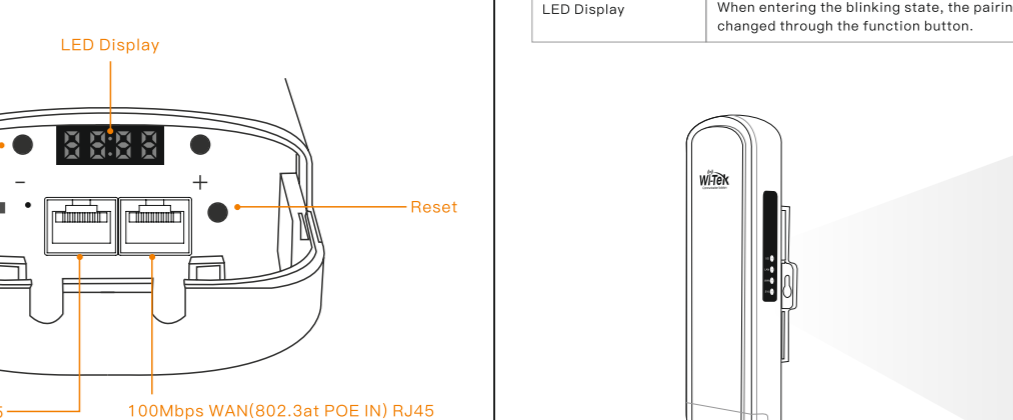

DIP Switch	Description
DIP Switch	H: Base station mode, supports wireless point-to-point and point-to-multipoint long-distance transmission. C: CPE mode, a receiving point for connecting a wireless base station.

Button	Description
"+" "−"	Press and hold the button for 3s to enable the pairing group adjustment function. When the LED Display starts to blink, press the button to raise the pairing group number. When the LED Display starts to blink, press the button to reduce the pairing group number.
Reset Button	Long press over 5 seconds: Restore the factory default configuration.

3.Mounting

- 1.Insert ribbon at the backside bracket hole.Adjuste it according to the pole size and installation position.
- 2.Install the device on the pole and tighten the ribbon.
- 3.Hold on the buckle to take down the device back cover. Insert the net cable into the network port, then fasten the back cover.

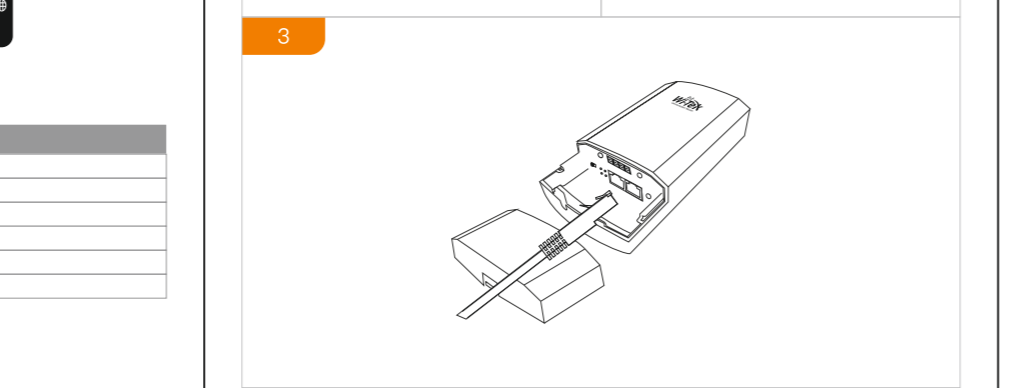
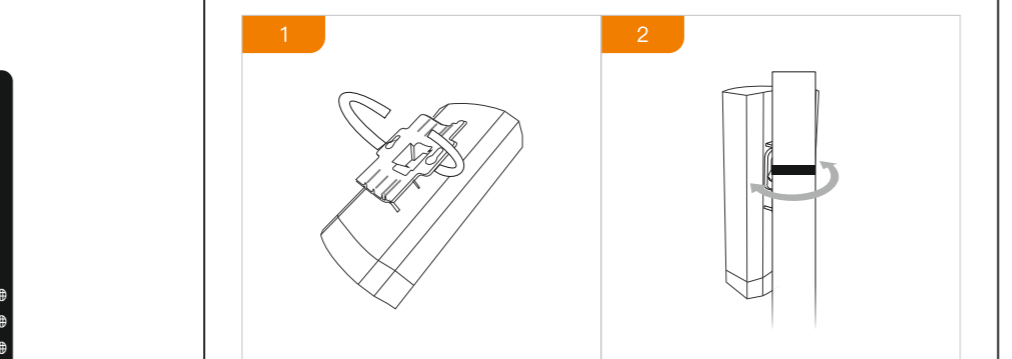

4.Network Application

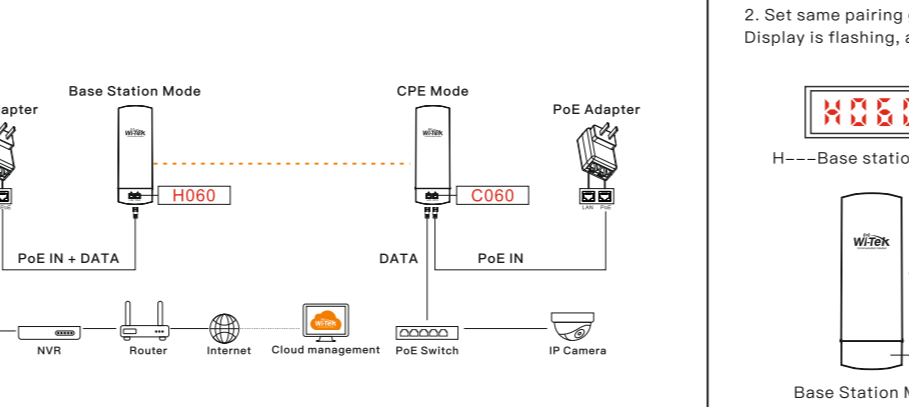

- Configuration steps
- 1. Set one device to Base station mode, and Another to CPE mode.

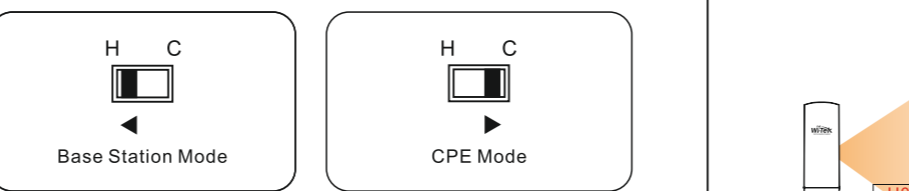

5.Management

Management by WEB

- A) Set the device to **Base Station Mode**.

Step 1. Set PC network IP to 192.168.1.X (X: 2-50), subnet mask: 255.255.255.0, same network segment as device. Launch the browser and enter the login page default IP: 192.168.1.88 or 192.168.1.89, set the administrator password.

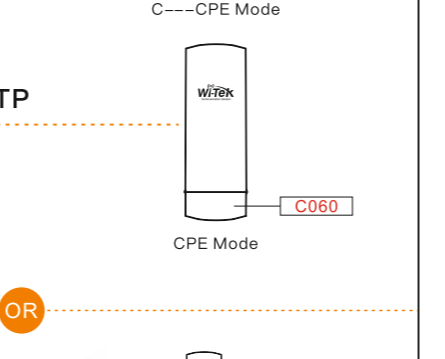

- Step 2. Go to the "Wizard" page, select <Base Station Mode>, and click <Next>.

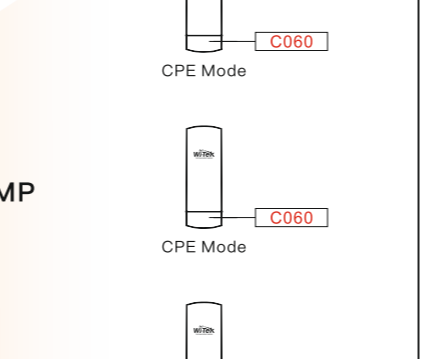

- B) Set the device to **CPE Mode**.

Step 3. Select the network protocol based on the network design. For example, select <Dynamic IP(DHCP)> and click <Next> in the "Select Network Protocol" page. Type in network parameters in the "WAN configuration" page, and click <Next>.

Step 4. Type in the <SSID>, <Encryption> and <Password> in "Wireless Configuration" page. Then click <Next>. Review the configurations and click <Confirm> to complete the wizard in the "confirm" page. The device will save the configuration and restart to switching mode.

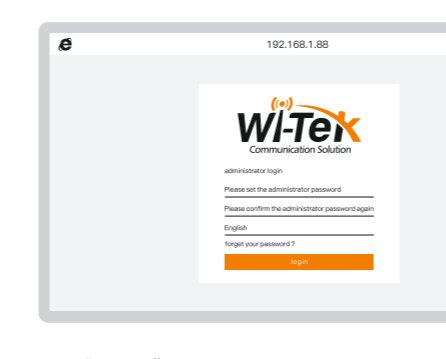

- Step 5. Repeat the A) step 1, login the management WEB. Go to the "Wizard" page, select <CPE Mode>, and click <Next>.

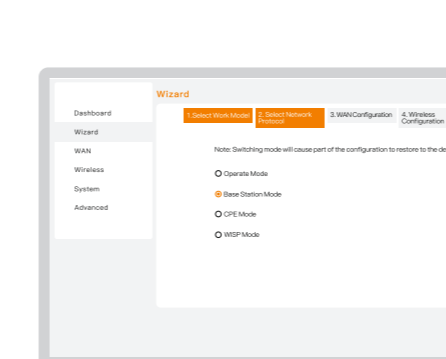

Step 6. Repeat the A) step 3, Specify the parameter in the "WAN configuration" page and click <Next>. Click <Start Scan> to search and select the base station wireless in the "Wireless Configuration" page.

Step 7. Type in the base station wireless parameter and click <Next>.

Step 8. Review the configurations and click <Confirm> to complete the wizard in the "confirm" page. The device will save the configuration and restart to switching mode.

6. Cloud Management

Make sure your device has access to the Internet. Enter https://cloud2.wireless-tek.com in the browser and log in to the cloud, add a network, or select the existing network. Go to "Device > CPE", click <ADD DEVICE >, enter the device's SN and last six hexes of the device MAC address, and click <ADD >. Wait a moment, you can find it in the device list and view it in "Topology".

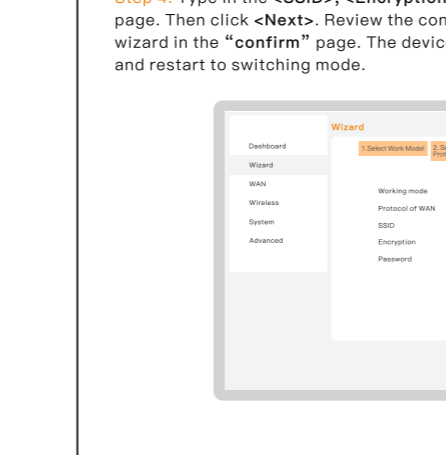
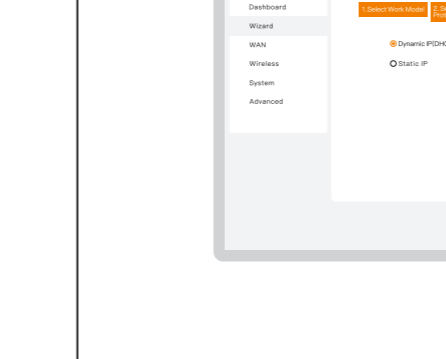
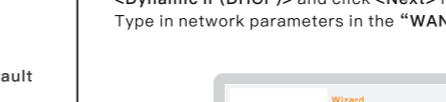

7.Warranty Card

Username	
Address	
Telephone No.	
Purchase Shop	
Purchase Address	
Product Model No.	
Purchase Time	
Serial No.	
Dealer Signature	

- If the product defects within the warranty period, we will provide professional maintenance service.
- Proof of purchase and a complete product serial number are required to receive any services guaranteed as part of the limited warranty.
- Any other defects that are not caused by workmanship or product quality, such as natural disasters, water damage, extreme thermal or environmental conditions, sticker damaged, warranty card loss will disqualify the product from limited warranty.

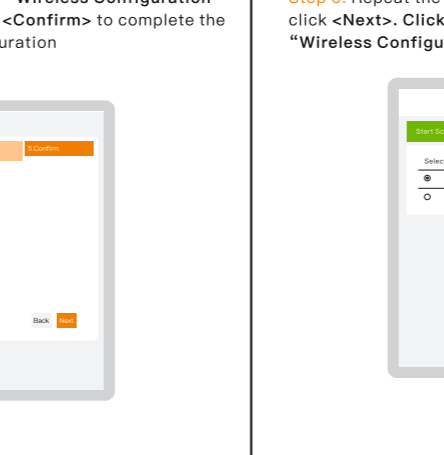

Company Website Cloud Management Technical Support

8. Cloud Management

Wireless-Tek Technology Limited
Address: Building 3, Units 1801-1807, 1812, Huaqiang Era Plaza, Tangwei Community, Fuhai Street, Bao'an District, Shenzhen City, Guangdong Province, China.
Website: www.wireless-tek.com
Tel: 86-0755-32811290
Email: sales@wireless-tek.com
Technical Support: tech@wireless-tek.com

