

# 1P Gigabit PoE Surge Protector

WI-SPD10KV-POE-A Thailand Project Version

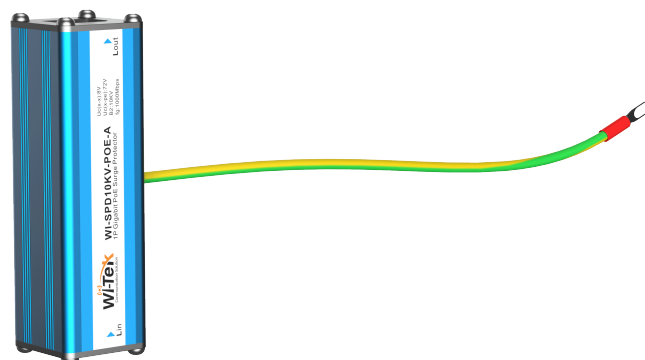

## Overview

This product adopts multi-stage protection circuit, high-quality high-speed protection component, low capacitance design, fast response, low output residual voltage, superior transmission performance. The interface adopts standard RJ45 shielded crystal head, which is suitable for the comprehensive protection of network cameras, signal ports and power ports of various network devices. By suppressing high-voltage pulses on the line, it protects the equipment from lightning and industrial surge damage.

## Features

- . Multi-stage Protection
- . Picosecond-level Response
- . Low Insertion loss
- . Gigabit Ethernet Port
- . Low Output Residual Voltage
- . Excellent Transmission Performance

# Specifications

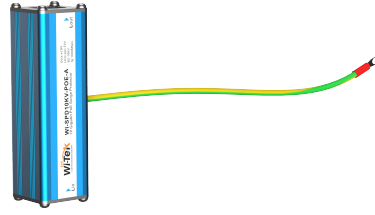

Model	Type	WI-SPD10KV-POE-A
Maximum Carrying Power	/	100W
Rated Operating Voltage	Un	48VDC(X-PE), 5VDC(X-X)
Maximum Sustainable Operating Voltage	Uc	72VDC(X-PE), 8VDC(X-X)
C2 Total Nominal Discharge Current (8/20μs)	Total	20kA
C2 Nominal Discharge Current Per Line (8/20μs)	In	2.5kA
C2 Maximum Discharge Current Per Line (8/20μs)	Imax	3kA
Protection Level: Line -PG (C10KV/2.5KA)	Up	250V
Transmission Rate	fg	1000Mbps
Response Time	tA	1ns
Insertion Loss	IL	≤0.3dB
Interface Form	/	RJ45
Number of Protection Lines	/	1, 2, 3, 6/4, 5, 7, 8
PoE Support	/	IEEE 802.3af/at, Mid-span and End-span
Housing Material	/	Aluminium alloy
Case Protection Class	/	IP20
Installation Mode	/	Desktop
Operating Temperature	°C	-40~85°C

WI-SPD10KV-POE-A

Dimensions (mm)

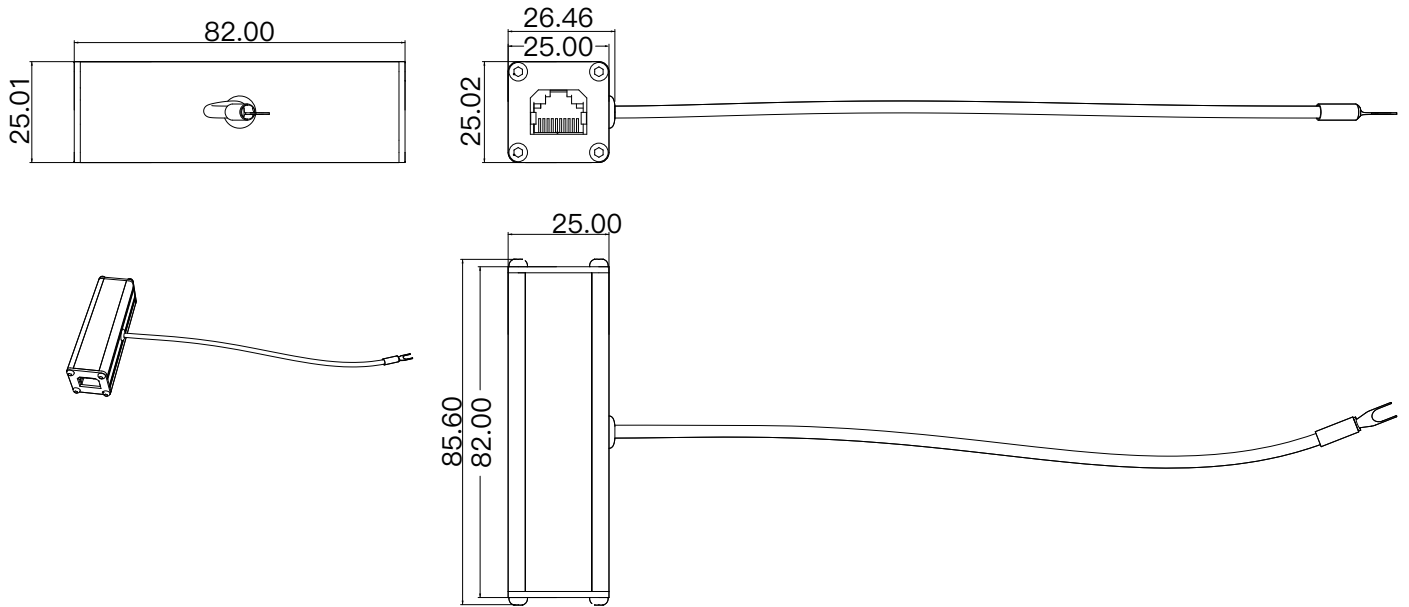

Application schematic diagram

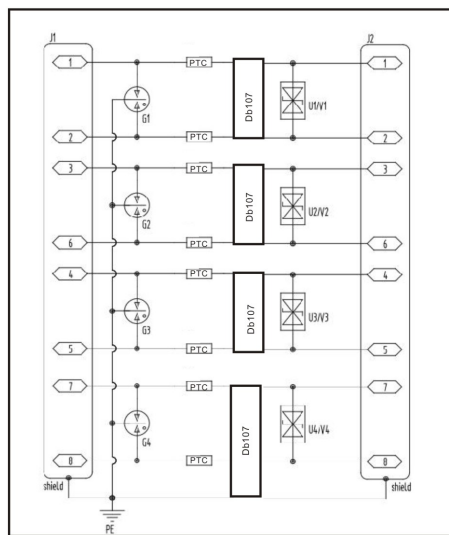

## WI-SPD10KV-POE-A

## Application Diagram

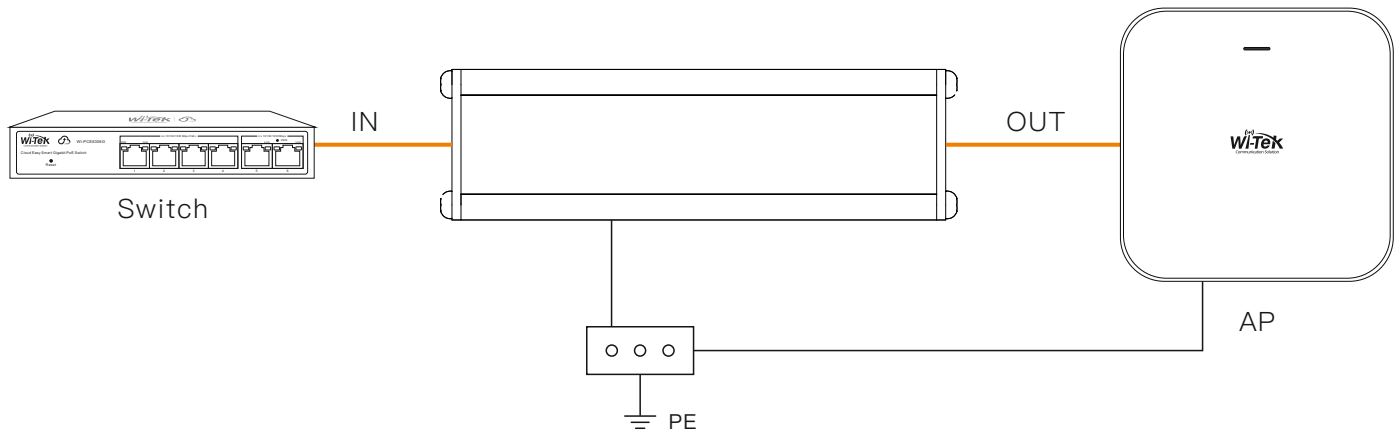
**Installation precautions for SPD:**

1. Safe connection of SPD: Before installing the surge protector, it is essential to ensure that the power supply is disconnected to prevent any electric shock accidents. When connecting the wires, pay attention to the fixation of the SPD and the protected equipment to ensure a safe and stable connection and avoid poor contact and other issues.
2. Installation distance of SPD: To ensure the safety of the protected equipment, the installation distance between the SPD and the protected equipment should not exceed 0.5 meters.
3. Interface cables for SPD: Select the appropriate gauge and type of cables based on the grade and interface type of the SPD.
4. Grounding requirements for SPD: For better protection of the equipment, each SPD must be independently grounded (note: it cannot share the ground wire with the power grid). The gauge of the grounding wire should be equal to or greater than that of the system cables, and the grounding resistance should be less than or equal to  $10\Omega$ .



Wireless-Tek Technology Limited

Address: Building 3, Units 1801-1807, 1812, Huaqiang Era Plaza, Tangwei Community, Fuhai Street, Bao'an District, Shenzhen City, Guangdong Province, China.

Website: [www.wireless-tek.com](http://www.wireless-tek.com)

Tel: 86-0755-32811290

Email: [sales@wireless-tek.com](mailto:sales@wireless-tek.com)

Technical Support: [tech@wireless-tek.com](mailto:tech@wireless-tek.com)

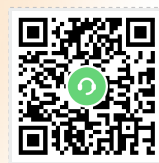

Technical Support



Cloud Management



Company Website