

100/1000Mbps Ethernet Switch

WK-S205 | WK-S208 | WK-S305 | WK-S308



Overview

Wi-Tek 100/1000Mbps Ethernet Switches provide 5/8 Ethernet RJ45 ports, which enhance your communication quality and supply high-performance, cost-effective, stable operating conditions for your network.

With all ports support Auto-MDI/MDIX, there's no need to worry about the type of cable to use. Featuring full duplex mode can send and receive data at a rate up to 1000 Mbps, making it an ideal choice for expanding your high performance network.

Features

Port Performance

All ports can achieve line-speed forwarding. Each port supports automatic MDI/MDIX reversal and self-negotiation of duplex/rate. It supports 802.3x full-duplex flow control and Backpressure half-negotiation of duplex flow control.

Plug and Play, No Configuration Required

A plug-and-play design lets administrators quickly connect the switch to devices with no hassles, no technician needed. Dynamic LED indicator lights provide simple working status prompts and fault detection.

Fanless Design

Fanless design, to provide you with a quiet working environment, suitable for office, hotel and other application scenarios.

Flexible Mounting, Anywhere Deployment

Supports both wall-mount and desktop installations for adaptability in any environment, saving time with flexible mounting options.

Specifications



Model	WK-S205	WK-S208	WK-S305	WK-S308
Interfaces				
Downlink Ports	5*10/100Mbps RJ45 Ports	8*10/100Mbps RJ45 Ports	5*10/100/1000Mbps RJ45 Ports	8*10/100/1000Mbps RJ45 Ports
Switch Property				
Standards and Protocols	IEEE 802.3i, IEEE 802.3u, IEEE802.3x, IEEE802.3az		IEEE 802.3i, IEEE 802.3u, IEEE 802.3ab, IEEE 802. 3x, IEEE 802. 3az	
Forwarding Mode	Store and Forward			
Switching Capacity	1Gbps	1.6Gbps	10Gbps	16Gbps
Packet Forwarding Rate	745Kpps	1.19Mpps	7.44Mpps	11.9Mpps
MAC Address Table	1k		2k	8k
Packet Buffer Memory	448Kbit		3Mb	4Mb
Jumbo Frame	1536Bytes		15KB	
Input Power	DC 5V 0.55A IN			DC 5V 1A IN
Physical Characteristics				
LED Indicators	<p>PWR Solid on: The power supply is normal Off: The system power supply is abnormal</p> <p>Link indicator Solid on: A link has been established on the interface Blinking: Data is being transmitted or received on the interface Off: No link is established on the interface</p>			
Fan Quantity	Fanless			
Switch Dimensions (W*D*H)	82*50*20mm	127*67*20mm	82*50*20mm	127*67*20mm
Package Dimensions	85*85*83mm	130*85*83mm	85*85*83mm	130*85*83mm
Weight	Net Weight: 0.040kg	Net Weight: 0.088kg	Net Weight: 0.040kg	Net Weight: 0.088kg
	Package Weight: 0.15kg	Package Weight: 0.20kg	Package Weight: 0.15kg	Package Weight: 0.20kg
Installation	Desktop, Wall-mount			
Environmental				
Surge Immunity	1kV			
Air discharge	8kV			
Operating environment	-10°C to 50°C(14°F to 122°F); 10%~90% RH no condensation			
Storage environment	-40°C to 70°C(-40°F to 158°F); 5%~90% RH no condensation			
Others				
Certification	CE, FCC, RoHS, UKCA, RCM			

Appearances and Dimensions

WK-S205

Dimensions (mm)

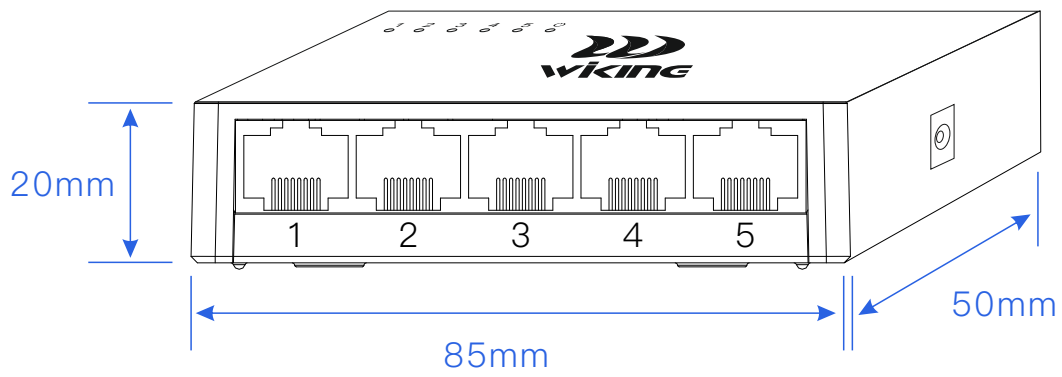

Front Panel

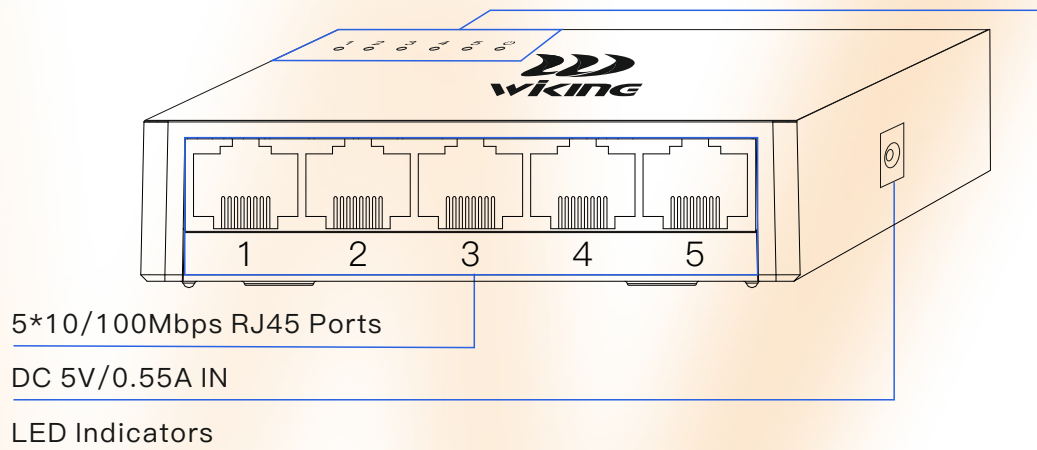

5*10/100Mbps RJ45 Ports

DC 5V/0.55A IN

LED Indicators

WK-S208

Dimensions (mm)

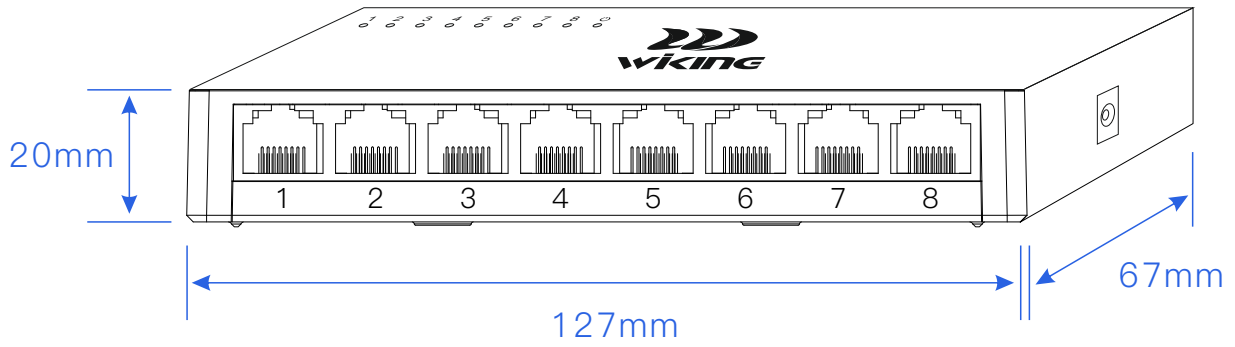

Front Panel

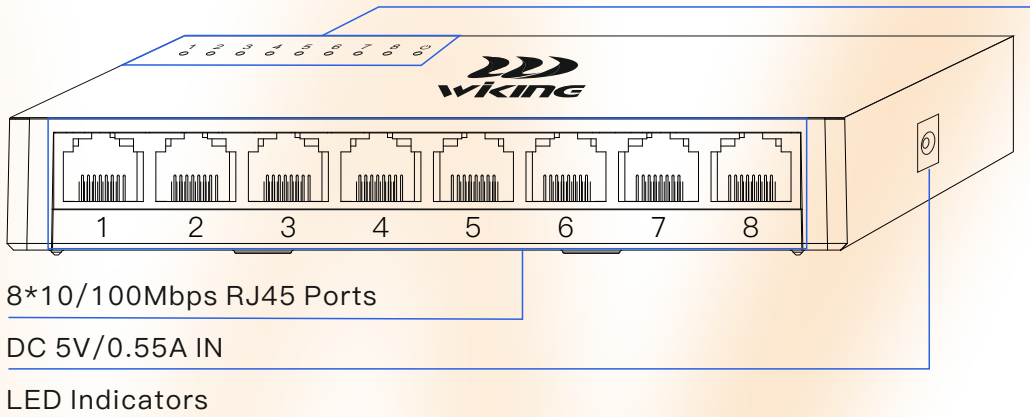

WK-S305

Dimensions (mm)

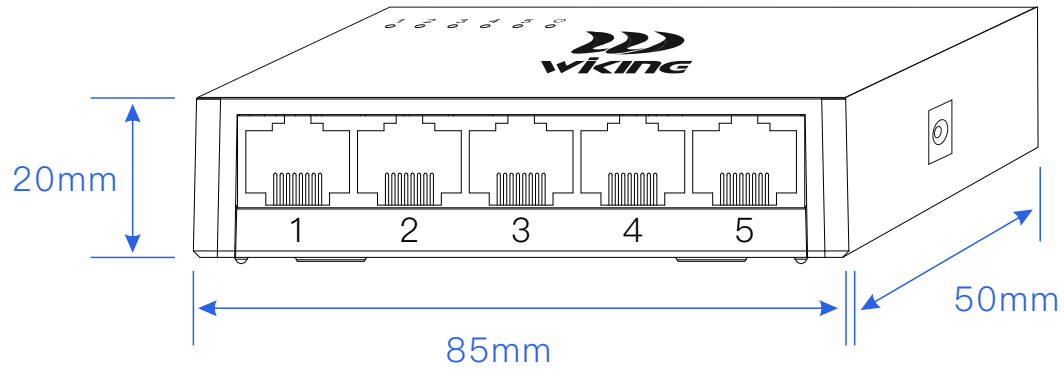

Front Panel

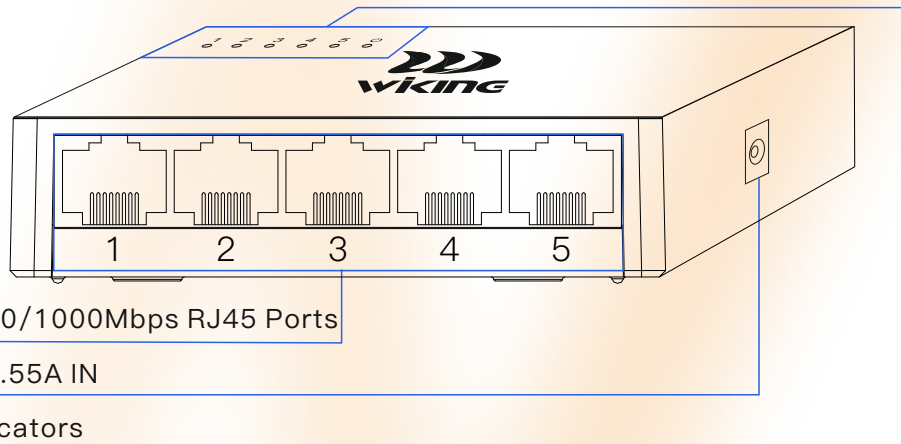

5*10/100/1000Mbps RJ45 Ports

DC 5V/0.55A IN

LED Indicators

WK-S308

Dimensions (mm)

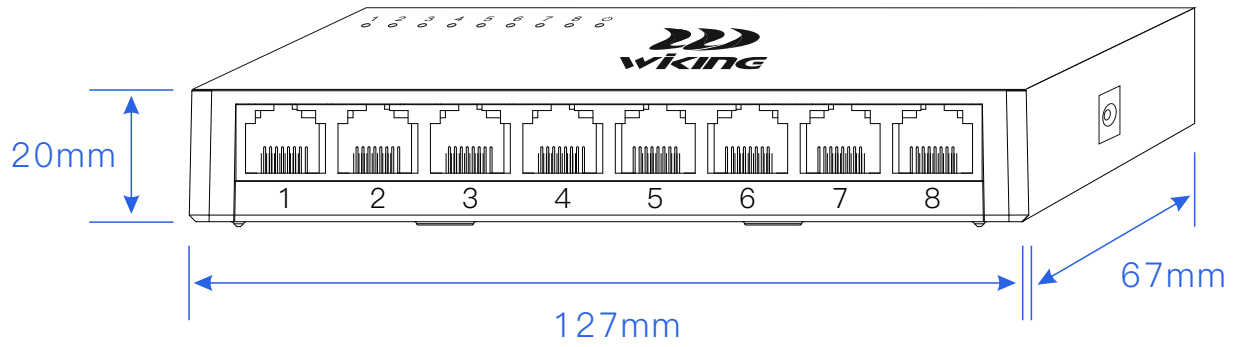

Front Panel

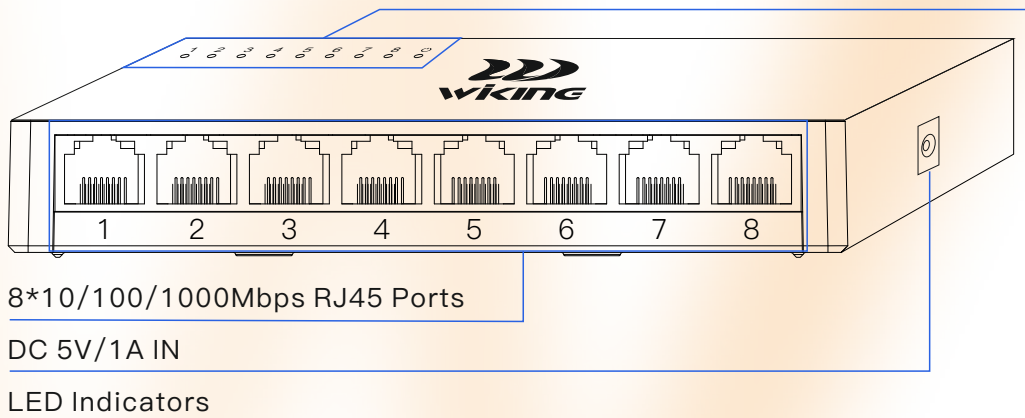

Package Contents

Welcome to order our products. After purchasing, you will receive:

Items	Quantity
Switch	1 pcs
Power Adapter	1 pcs
Quick Installation Guide	1 pcs



Wireless-Tek Technology Limited

Address: Building 3, Units 1801-1807, 1812, Huaqiang Era Plaza, Tangwei Community, Fuhai Street, Bao'an District, Shenzhen City, Guangdong Province, China.

Website: www.wireless-tek.com

Tel: 86-0755-32811290

Email: sales@wireless-tek.com

Technical Support: tech@wireless-tek.com

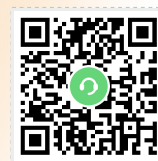

Technical Support



Cloud Management



Company Website